

Features:

O-Ring energizer that maintains seal force throughout service life

Double-acting design

Side notches ensure pressure exposure to the energizer during rapid pressure changes

Easy to install



MATERIAL

The 416 series rotary seal features custom blended PTFE-filled compound providing ultra-low friction and high-speed performance with minimal wear. The standard compound is Glass-Moly and NBR. The temperature range of the seal can be increased by selecting an FPM energizer in place of the standard NBR energizer.

Material	Code
PTFE-Glass/MoS ₂ compound + NBR O-Ring (shown in photo)	MT83
PTFE-Glass/MoS ₂ compound + FPM O-Ring	MT86
PTFE/Carbon/Graphite + NBR	MT62
PTFE/Carbon/Graphite + FKM	MT67
PTFE/Carbon + FKM	MT77
PTFE/Carbon + NBR	MT160
UHMW + NBR	ML11

OPERATING PARAMETERS

Temperature	MT83	
	°C	°F
hydraulic oil	-30... +100	-22... +212
water oil emulsions (HFA)	+5... +60	+40... +140
water-glycol fluids (HFC)	-30... +60	-22... +140
polyol esters (HFD)	-	-
water	+5... +100	+40... +212
speed	0.5 m/s (1.65 ft/sec)	
pressure	400 bar (6,000 psi)	

Note: for other materials or fluids please contact our engineering department.

DESCRIPTION

The 416 series PTFE rotary swivel seal is a low-friction design, consisting of a PTFE-filled seal and an O-Ring energizer. It is designed for rotary swivel applications, where low friction, low torque and high wear resistance are needed.

PRODUCT BENEFITS

- Low friction
- Rotary swivel applications
- High-temperature resistance
- Low wear
- Low torque
- Extrusion resistant
- Compatible with a wide range of media
- Available in diameters up to 2100 mm
- High abrasion resistance

APPLICATIONS

The 416 series rotary seal is ideal for high-pressure sealing applications, offering low-friction performance and rotary swivel operation.

Typical applications include:

- Rolling Mills
- Hydraulic Motors
- Agricultural Hydraulics
- Mobile Hydraulics
- Pivoting Motors
- Steel Mill Coilers
- Rotary Actuators
- Rotary Swivels

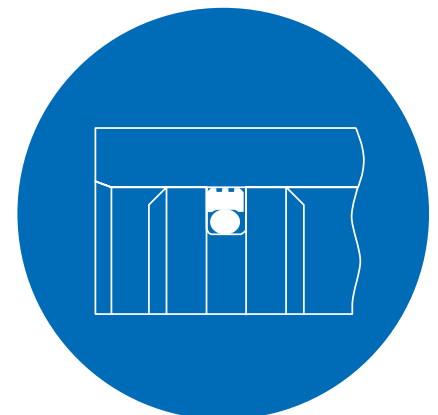

Above: Installation Drawing

DESIGN GUIDELINES

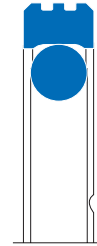
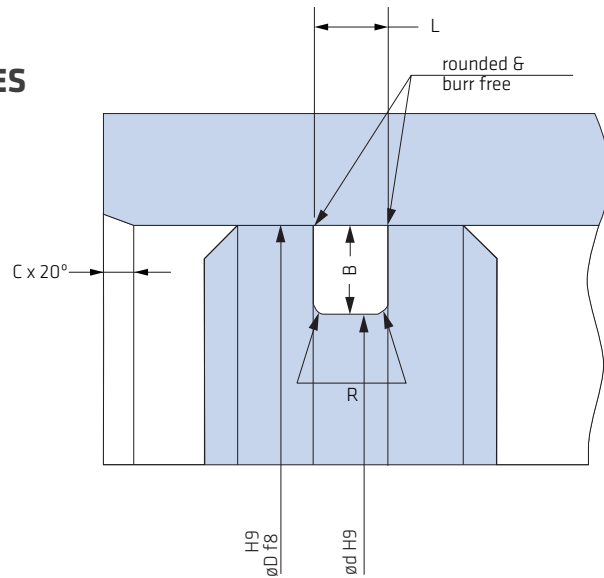

METRIC SERIES

	B	$\varnothing d$	$L^{+0.20}$	R
Series 1	3.75 mm	D - 7.50	3.2	0.50
Series 2	5.50 mm	D - 11.00	4.2	0.80
Series 3	7.75 mm	D - 15.50	6.3	1.20
Series 4	10.50 mm	D - 21.00	8.1	2.00
Series 5	14.00 mm	D - 28.00	9.5	2.00

INCH SERIES

	B	$\varnothing d$	$L^{+0.008}$	R
Series 1	0.148 in	D - 0.295	0.126	0.020
Series 2	0.217 in	D - 0.433	0.165	0.030
Series 3	0.305 in	D - 0.610	0.248	0.050
Series 4	0.413 in	D - 0.827	0.319	0.080
Series 5	0.551 in	D - 1.102	0.374	0.080

Note: the extrusion gap "E" is suitable for pressure up to 400 bar (6,000 psi) and temperatures up to 80° C (176° F). For higher pressures or temperatures, please consult our engineering department for guidance. For a complete list of available sizes please refer to the System Seals online product catalogue at www.systemseals.com.

SURFACE FINISH

Surface roughness	Ra	Rt	RMS
Sliding surface	0.05 - 0.30 μm	≤ 3.0 μm	8 RMS
Surface of groove I.D.	≤ 1.8 μm	≤ 10.0 μm	64 RMS
Sides of groove	≤ 3.0 μm	≤ 16.0 μm	125 RMS

LEAD-IN CHAMFERS

$\varnothing D$	C
$\leq 50\text{mm}$	3.00
50mm < 120mm	4.00
120mm < 200mm	6.00
200mm < 650mm	8.00
650mm < 950mm	11.00

$\varnothing D$	C
$\leq 2.0\text{in}$	0.120
2.0in < 4.7in	0.160
4.7in < 7.9in	0.240
7.9in < 25.6in	0.320
25.6in < 37.5in	0.450